

PSO3

MECCANISMO PER MOBILI CON PORTE SCORREVOLI IN LUCE

- facilità di lavorazione del pannello;
- semplicità di montaggio;
- possibilità di regolazione verticale delle porte senza l'uso di alcun attrezzo;
- utilizzo di arresti fine corsa inseriti nel binario.

MECHANISM FOR FURNITURES WITH INSIDE SLIDING DOORS

- easy manufacturing of the panel;
- simple assembling methods;
- possibility of vertical adjustment of the doors without using any tool;
- use of end-run stops inserted in the rail.



**FERRAMENTA PER MOBILI
FITTINGS FOR FURNITURES**

ISTRUZIONI DI MONTAGGIO
MOUNTING INSTRUCTIONS

- 1** Inserire i fermi nei binari (superiore ed inferiore).
2 Inserire i binari nel fondo e nel cappello del mobile.

- 1** Insert the locks into the rails (upper and lower).
2 Insert the rail into the grooved top and bottom of the furniture.

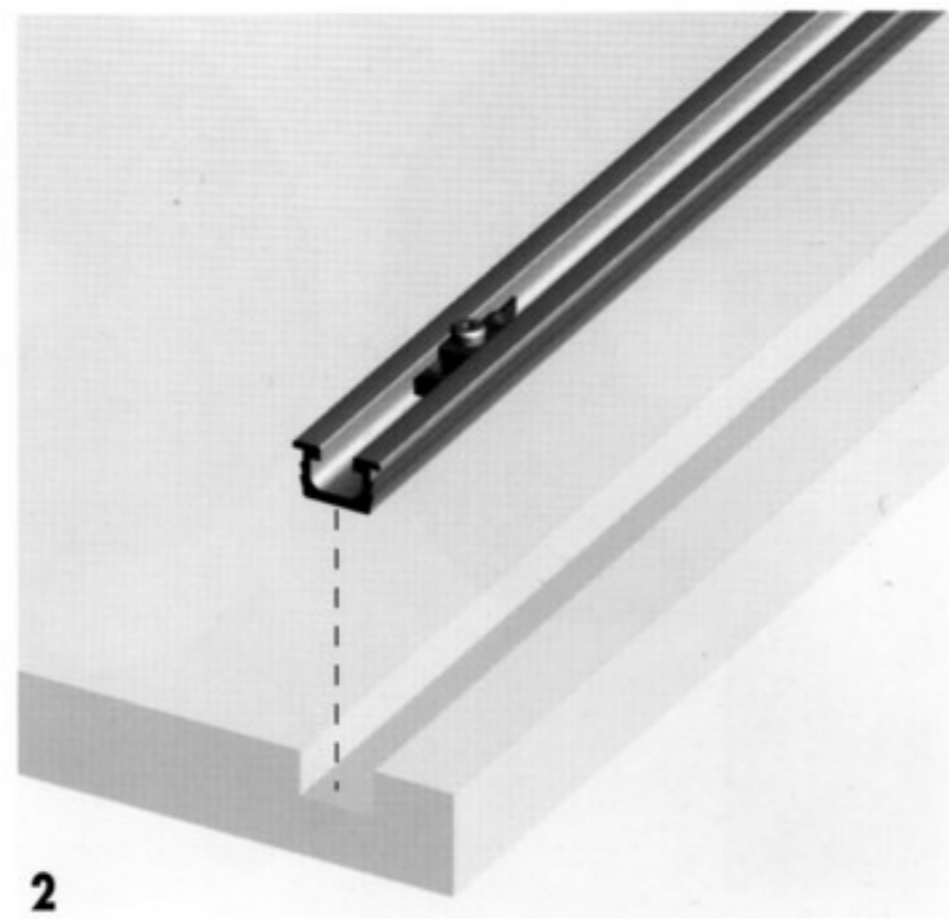
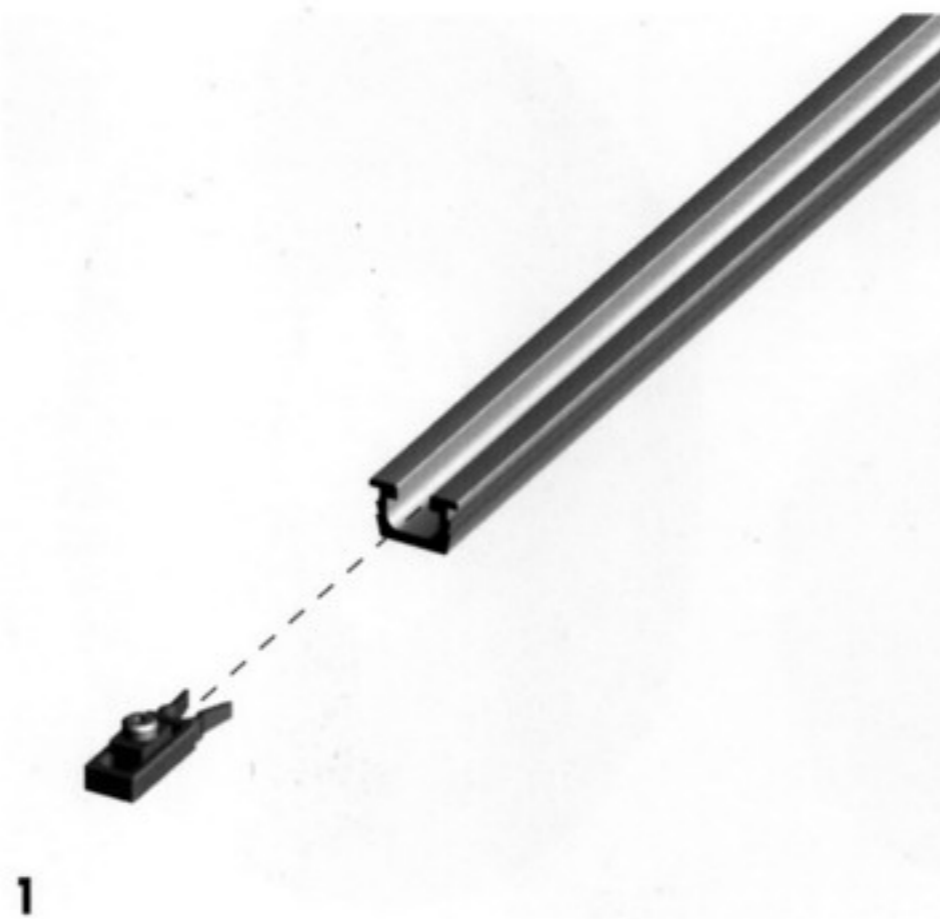

- 3 - 4** Inserire i pattini inferiori e superiori nelle apposite sedi fresate dell'anta in legno o in vetro con profilo di alluminio.

- 3 - 4** Insert the upper and lower slides into the proper seats ready grooved on the wooden door or on the aluminium frame profile.

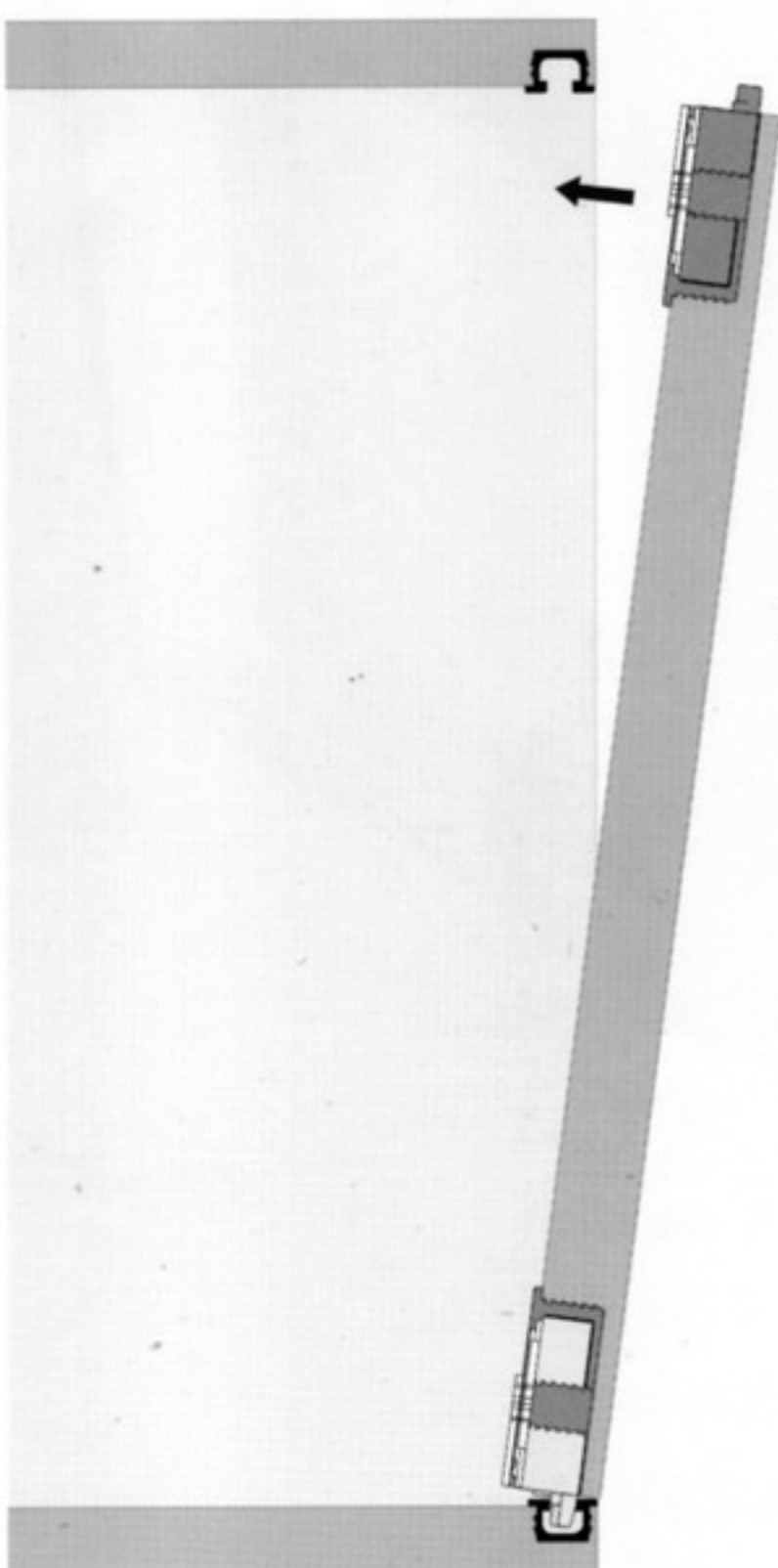
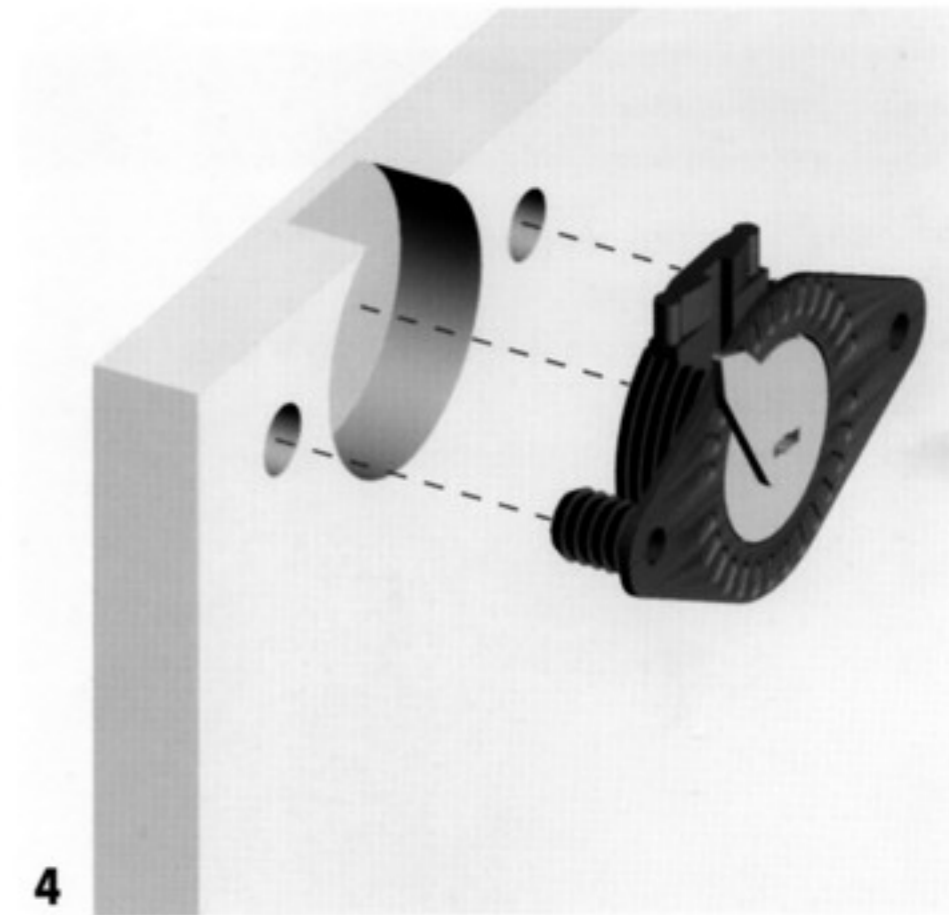
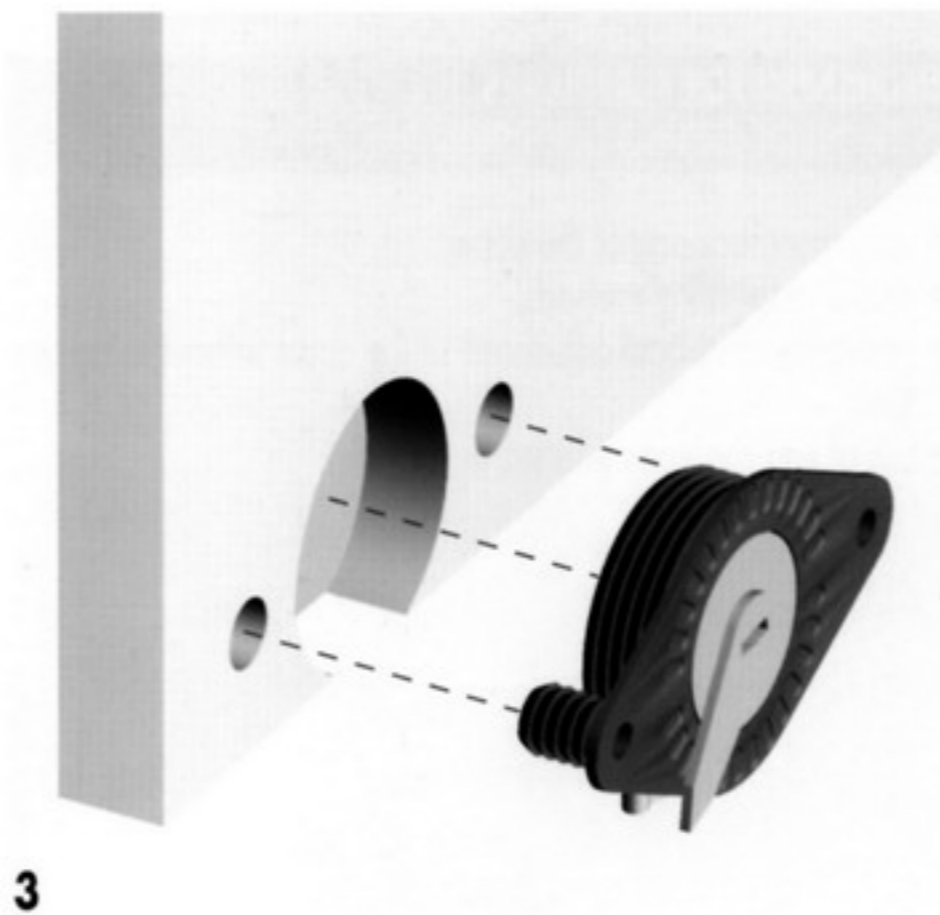

- 5** Inserire la pinna sporgente del pattino inferiore nel binario.

- 5** Insert the fin of the lower slide into the rail.

5

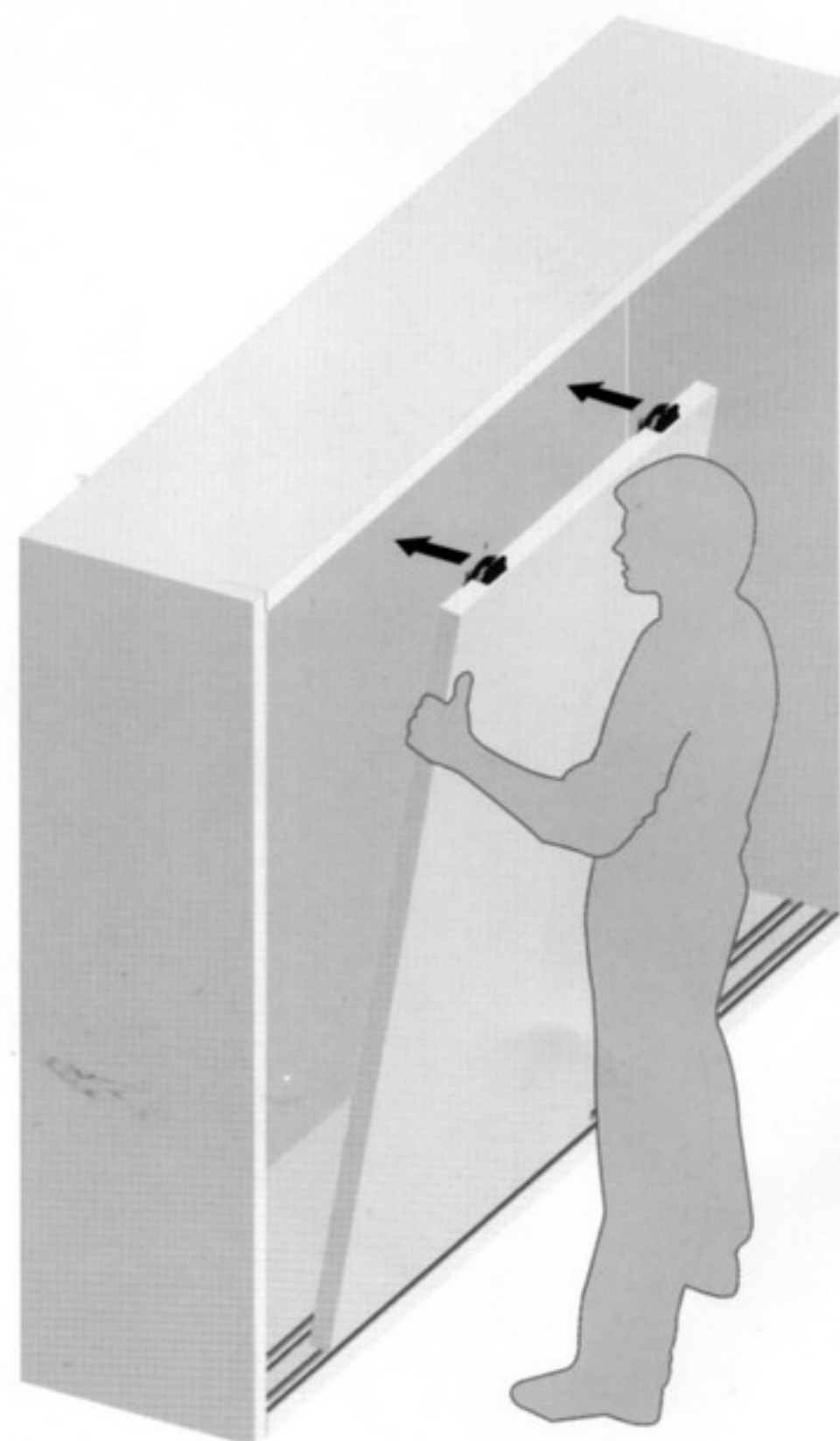

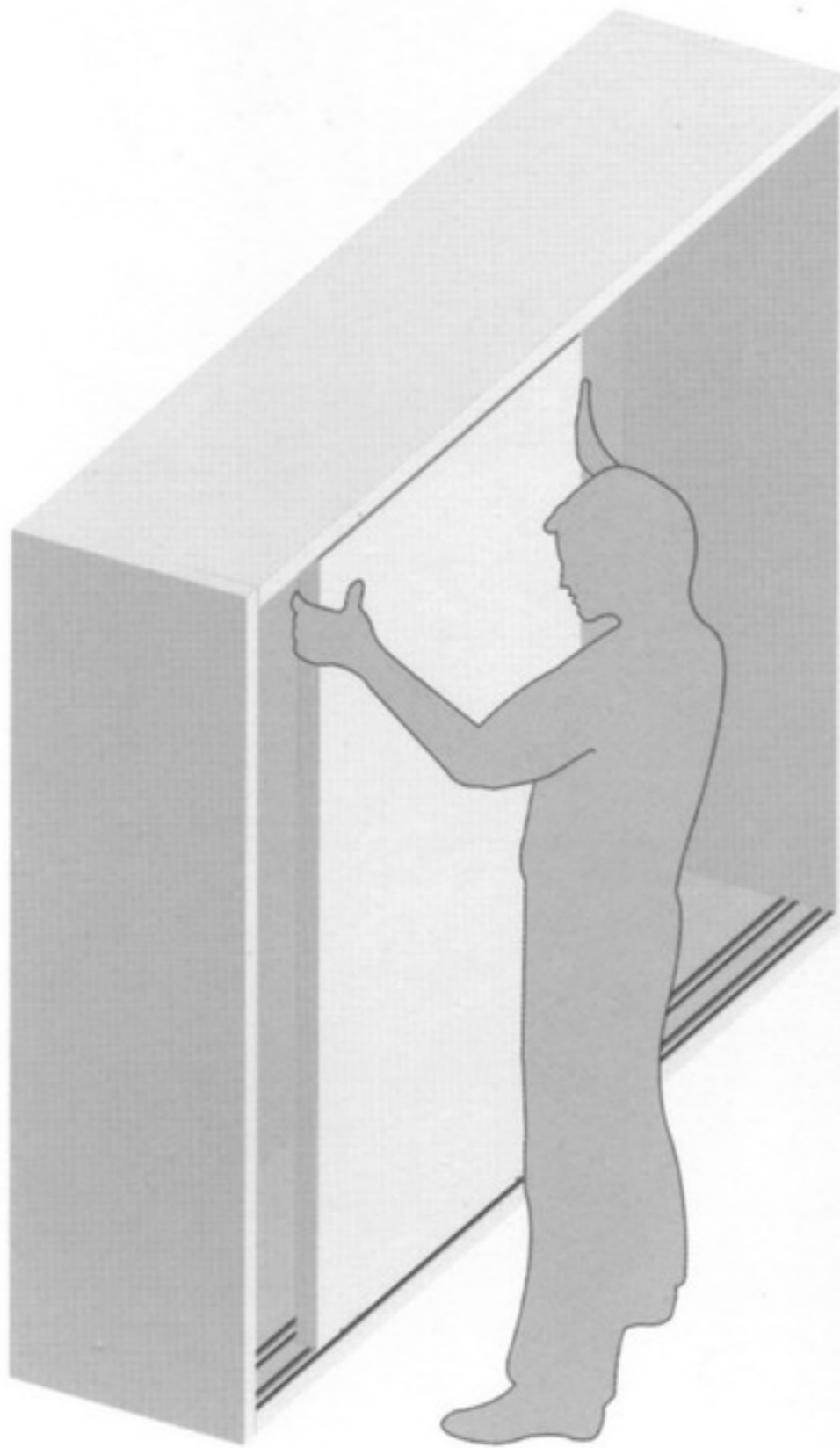
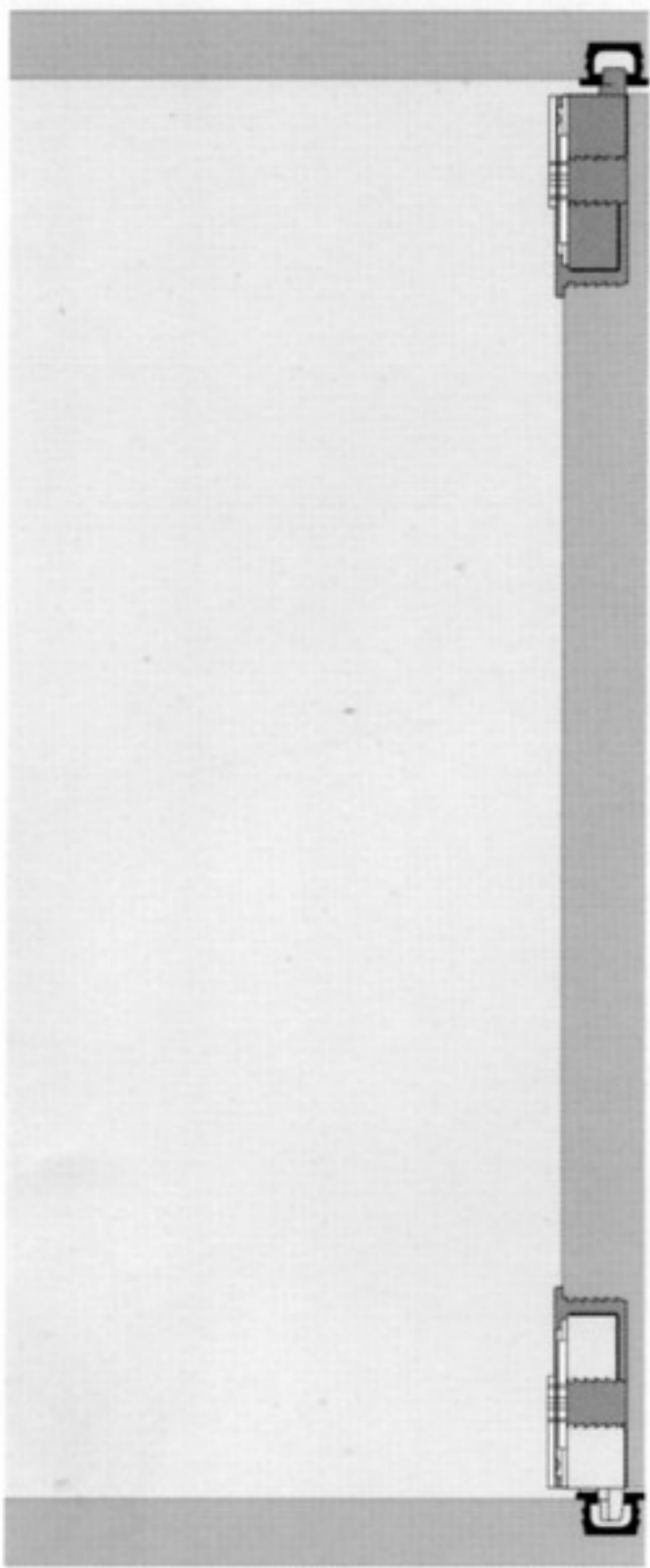

6 Posizionare verticalmente la porta e far entrare la pinna del pattino superiore nel binario superiore ruotando manualmente la leva.

6 Position vertically the door and let the fin of the upper slide into the rail rounding manually the lever.

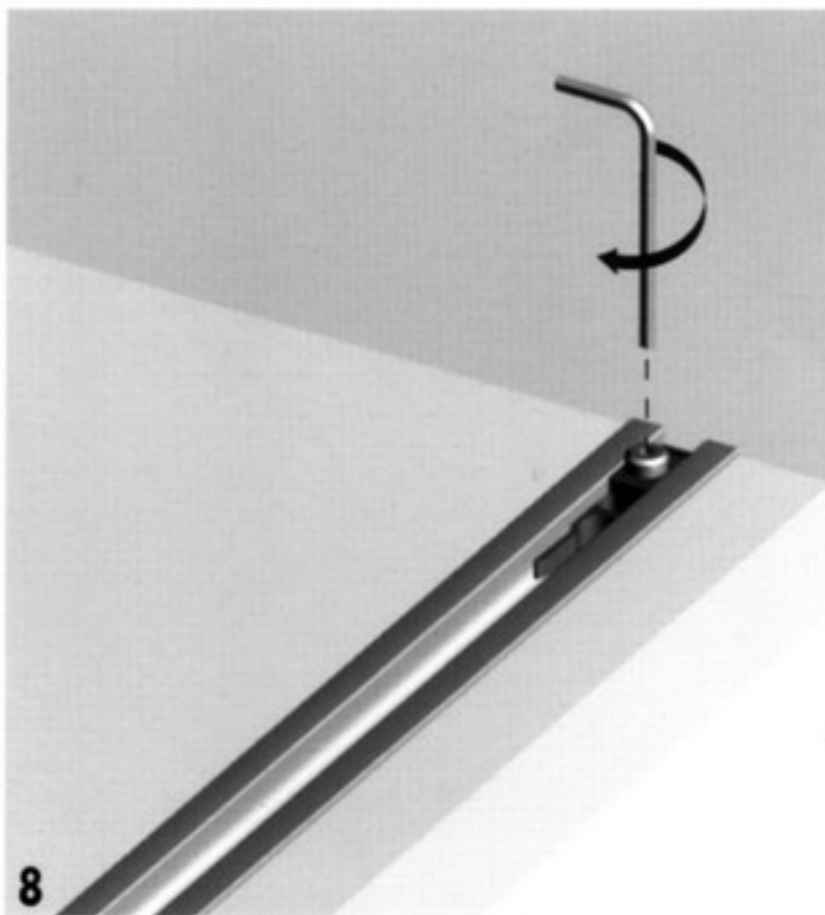
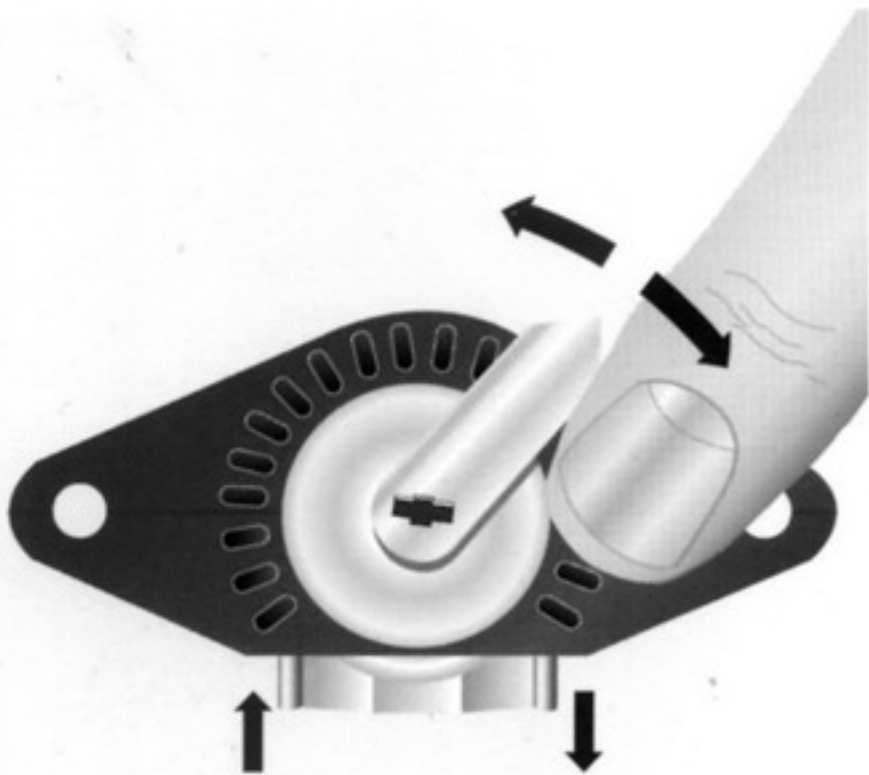

7 Per regolare la porta in altezza, ruotare manualmente la leva dei pattini inferiori.

8 Posizionare i fermi e bloccarli tramite l'apposito grano premontato.

7 To adjust the door on height, rotate manually the lever of the lower slides.

8 Position the locks along the rails and fix them with the proper nut ready assembled.

6



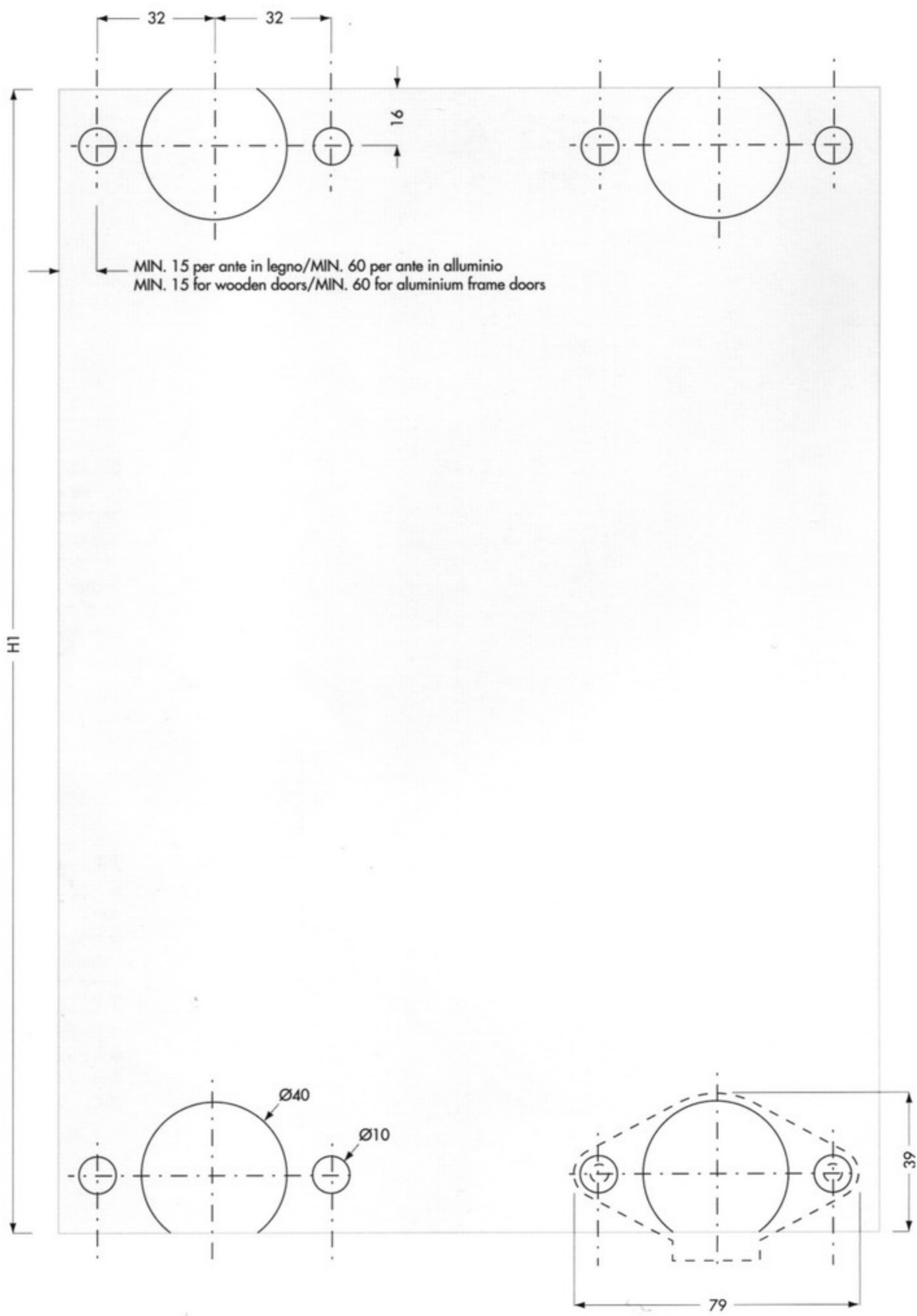

7

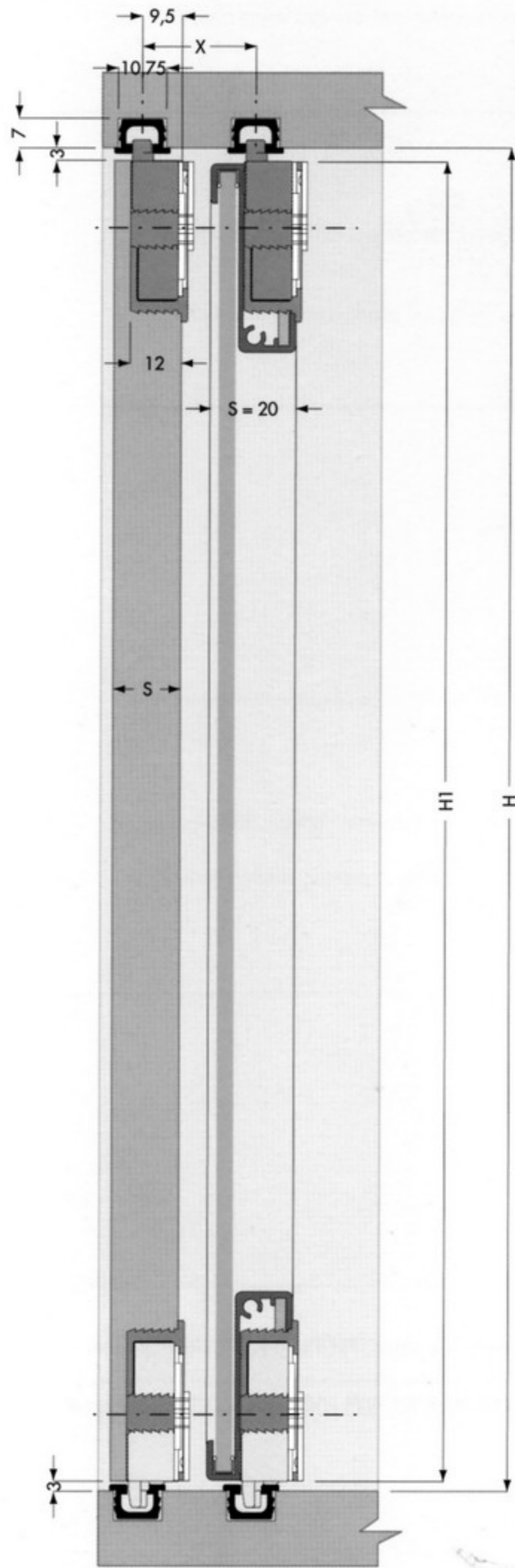
8



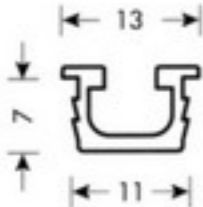
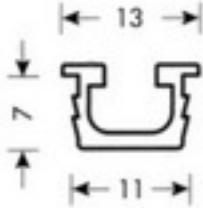

$H - H1 = 3 + 7$
 $X_{MIN.} = S + 5$

COMPONENTE COMPONENT	DESCRIZIONE DESCRIPTION	FINITURA FINISH	CODICE CODE
	Binario superiore - inferiore alluminio lung. standard mm. 6100 Upper - lower aluminium rail standard length mm. 6100	Naturale Raw	PR0370003A
	Binario superiore - inferiore plastica lung. standard mm. 4050 Upper - lower plastic rail standard length mm. 4050	Bianco Marrone Nero White Brown Black	PR0383001A PR0389001A PR0390001A
	Pattino superiore Upper slide	Nero Black	PS03PS9001
	Pattino inferiore con regolazione - portata 400N/per porta Adjustable lower slide - load capacity 400N/per door	Nero Black	PS03PI9001
	Fermo Lock	Nero Grigio Black Grey	PS03FE9002 PS03FE8B02

Per la realizzazione di ante in profilo di alluminio consultare il depliant "PROFILATI PER ANTINE" presente nel capitolo ANTE.

To obtain aluminium frame door please see leaf-let "ALUMINIUM PROFILES FOR FRAME DOORS" in chapter FRAME DOORS.